



 **NOVAWINCH<sup>®</sup>** Branded Opportunities

 **NOVAWINCH<sup>®</sup>**



*Introducing:*



Stinger is our new workhorse series featuring proven parts, great performance and a fresh new look.





#### HIDING A SECRET

Compact, relocatable, integrated control box, protects sealed electronics and safely houses wireless remote receiver.

#### UPGRADED GEARS

Bigger cut-metal gears are the star in our trusted 3-stage planetary gearset

#### ANTI-KNOCK CLUTCH

Precise spring-pin keeps the clutch safe from unintended turns

#### UPGRADED MOTOR

Fatter copper windings deliver more power with ease and cool faster.

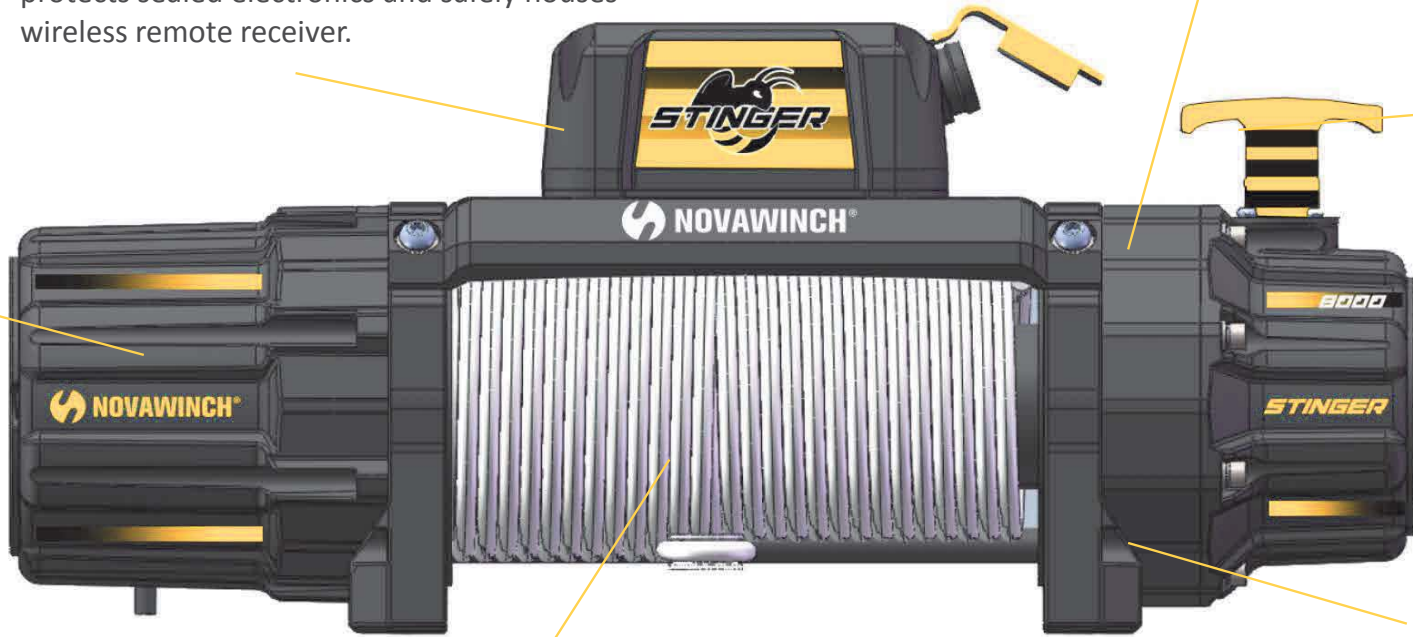

#### UPGRADED DRUM

Our techs flawlessly weld flanges to our oversized drum tube for maximum security for today's advanced ropes. Combined with our exclusive massive drive spline, it's the industry's best combo.

#### EARN'S OUR IP68 RATING

Rated means it's waterproof and submersible





## Stand Out Features

### COMPATIBLE

- 90° Clockable Motor makes installation easier for customers and fewer returns for fitment
- Relocatable control box
- Improved foot design increased stability + better fitment

### VALUE

- New! Novawinch DUO-Braid Rope features color flash plus reflective strips for nighttime safety
- Series is compatible with Novawinch standard 4-Pin socket for maximum remote support

### PROTECTED

- Overload protection prevents >rated-load pulls. Set by circuit breaker.
- Branded and stronger tie bar imparts quality.

### FRESH



Stinger™  
Motor-End  
Design

# 2

Versions

STINGER™



### Entry Version

- Standard Wired Remote
- Standard Yellow Synthetic Rope
- IP67 Rated

8,000

10,000

12,000

STINGER +



### PLUS Version

- DUO Wireless/Wired Remote
- Upgraded DUO Synthetic Rope
- IP68 Rated

8,000

10,000

12,000



STINGER™

- Drawing and Size
  - Stinger™
  - Stinger+

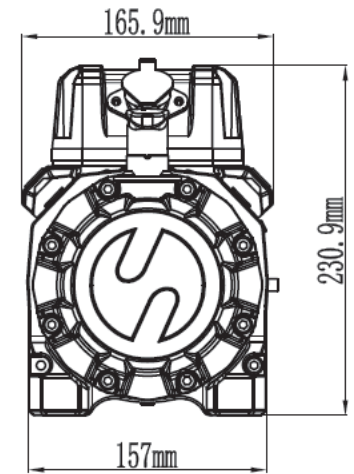
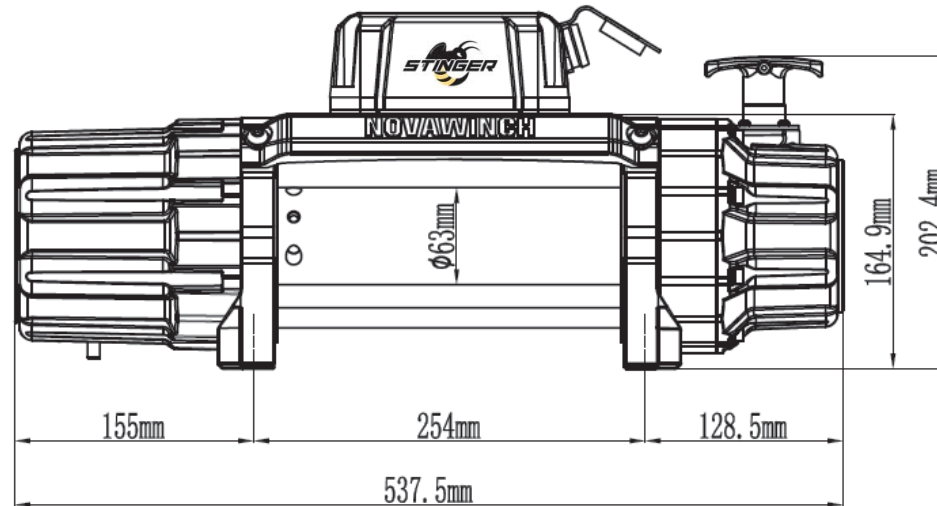
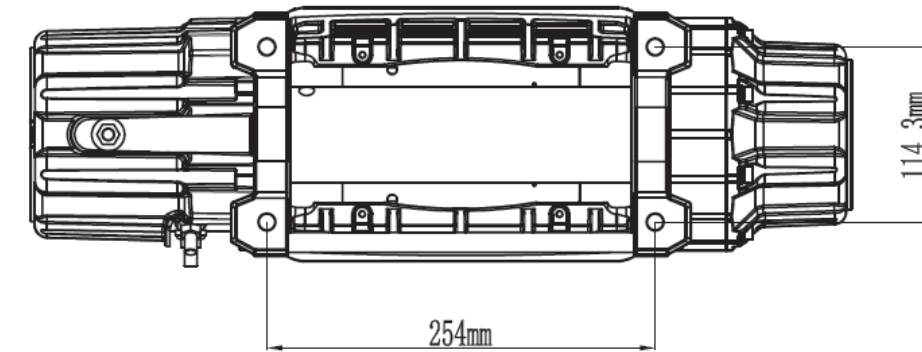

DC Powered Electric Winch —8000-12000Lb. Capacity





# 12,000

SPECIFICATIONS	
Rated line pull:	12000lbs(5443kgs)single line
Motor:	Series Wound DC 12V: 7.3hp/5.5kW
Gear train:	3-stage planetary
Gear ratio:	196:1
Clutch:	Anti-Knock Pull and turn
Braking action:	Mechanical, Automatic load holding
Fairlead:	Wire: 4-way roller fairlead Synthetic: Aluminum Hawse
Cable	Wire: 3/8"×85.3'(9.2mm×26m) Synthetic: 3/8"×85.3'(9.2mm×26m)
Drum size:	2.48"×8.8"(63mm×224mm)
Dimensions:	21.25"×6.49"×9.05"(540mm×165mm×230mm)
Bolt pattern:	10"×4.5"(254mm×114.3mm)
Net Weight:	Wire: Synthetic:

PERFORMANCE: 12V DC Line speed and motor current (first layer)				
Line pull		Line speed		Motor current
LBS	KGS	FPM	MPM	Amps
0	0	20.0	6.7	80
12000	5443	3.28	1.1	450

LINE PULL AND CABLE CAPACITY				
Layer of cable	Rated line pull per layer		Cable capacity per layer	
	Lbs	Kgs	Ft	M
1	12000	5443	17.7	5.4
2	9563	4342	40.4	12.3
3	7949	3609	66.9	20.4
4	6801	3087	85.3	26



Our focus on quality and innovation is poured into every product we make.

