



ELECTRIC WINCH

NVT8000 NVT8000-S

NVT10000 NVT10000-S

NVT12000 NVT12000-S

PLEASE READ CAREFULLY BEFORE OPERATE THE WINCH



1689 Xianyuan Road, Jinhua, Zhejiang, China
Tel:0086-579-82262697
Fax:0086-579-82262706
<http://www.nowwinch.net>
E-mail: info@nowvow.net

Description	Quantity
Winch assembly with wire rope	1
Hook and Handsaver	1
Remote Switch	1
Roller Fairlead	1
Mounting Hardware	1

SAFETY PRECAUTIONS

The responsibility for safe installation and operation of this winch ultimately rests with you, the operator. Read and understand all safety precautions and operating instruction before installing and operating the winch. Careless winch operating can result in serious injury and/or property damage. Never obscure or remove the warning or instruction labels.

Throughout this manual, you will find notations with the following headings:

▲ DANGER Indicates an imminently hazardous situation which, if not avoided, will result in death or serious injury.

▲ WARNING Indicates a potentially hazardous situation which, if not avoided, could result in death or serious injury.

▲ CAUTION Indicates a potentially hazardous situation which, if not avoided, may result in minor or moderate injury. This notation is also used to alert against unsafe practices.

Note: Indicates additional information in the installation and operation procedures of your winch

The following symbols on the product and in the Owners manual are used:



Read Owner's Manual



Always Use Handsaver



Keep clear of winch, wire rope and hook while operating



Never Use winch to lift or move people



Never Use winch to hold loads in place

Correct installation your winch is a requirement for proper operation.

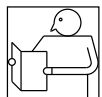

Observe safety precautions for personal safety and the safety of others. Improper equipment operation may cause personal injury and equipment damage.

Read the following carefully before attempting to operate your winch and keep the instructions for future reference.

▲ WARNING Never connect DC powered winches to AC current. Motor damage or fatal shock may occur.

1. Never lift people or hoist loads over people. Do not lift items vertically. The winch was designed for ground use only.
2. Never overload. Be sure all equipment used meets the winch's maximum line pull rating. We recommend using the pulley block option supplied to double line the wire rope (see Figure 1). Double line with a pulley block to reduce the load on the winch, wire rope and battery. When double-lining, pulley blocks should be rated to a minimum of two times the winch's line pull rating.

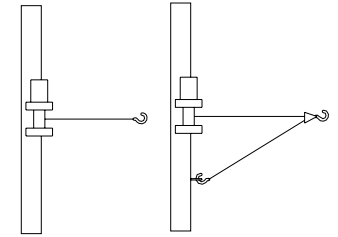

Figure 1

3. The cable may break before the winch stalls. For heavy loads, use a pulley block to reduce the load on the cable.
4. Never operate winch less than 5 turns of wire rope around the winch drum since the wire rope end may not withstand full load.
5. Avoid continuous pulls from extreme angles because this will cause the wire rope to pile up on one end of the drum (see figure 2) and damage the wire rope.
6. Be aware that the winch's line pull capacity is the maximum line pull of the first layer. That can only be reached by first layer cable on the winch. Never operate a winch pulling a load that is at or over the rated capacity.

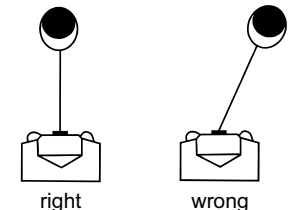

Figure 2

7. Never hook the wire rope back to itself because it could damage the wire rope. Use tree trunk saver (see Figure 3)
8. Be sure the winch is mounted hard on the vehicle or bracket before operation.
9. Before moving a load, inspect wire rope. Prevent kinks and uneven wire layer before they occur. Loosened wire rope must be properly tensioned under a load of about 100lbs.

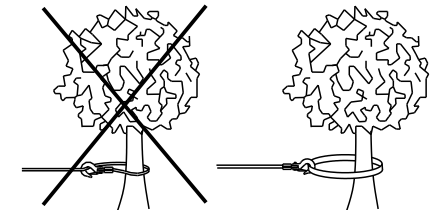

Figure 3

10. It is important to lay a blanket or jacket over the wire rope near the hook end when pulling a load (see figure 3). This will slow the snap back of a broken wire rope and help to prevent serious injury and damage.
11. Do not move your vehicle to assist the winch in pulling the load. It will be easy to overload and cause wire rope damage.
12. Beware of the danger zone. Keep away from the danger zone during operation. The danger zone is the area of the winch drum, the fairlead (if fitted), the wire rope, the pulley block (if used), the hook and the motor.
13. Never approach or span the wire rope when the winch is under load.
14. When using your winch to move a load, place the vehicle transmission in neutral, set vehicle brake, and chock all wheels. The vehicle engine should be running during winch operation so that the battery has full electricity. Never use winch under circumstance of lacking voltage.
15. Never disconnect free spool clutch when there is a load on the winch.
16. After operation, release the load immediately. Do not allow the cable to tighten anymore.
17. Always stand clear of wire rope, hook and winch.
18. Inspect winch, wire rope, hooks and other accessories frequently. A frayed wire rope

with broken strands should be replaced at once. Use heavy leather gloves when handling wire rope. Do not let wire rope slide through your hand. Inspect wire rope before use. Mashed, pinched, frayed or kinked areas severely reduce the load carrying capability. You should replace damaged wire rope. The replacement ropes must be re-spooled under a load of about 100lbs.

19. You should disconnect the clutch first, then use hand-saver strap to hitch the hook to pull the wire rope. Never pull wire rope using your finger and do not put your finger through the hook.
20. Keep tension on cable to re-spool the cable on the drum tightly after operating.
21. Do not operate winch when under the influence of drugs, alcohol, or medication. If there is something wrong, you should cut the battery at once, then check it carefully.
22. Wear eye protection and insulated work clothes, slip-proof shoes, work cap (to keep hair away from winch), and thick leather gloves. You should remove all jewelry.
23. Do not machine or alter any part of the winch.
24. Take good care of the winch when it is not in use.

▲ WARNING Unplug remote control before working in or around fairlead or wire rope drum (danger zone). Never tuck hand control under arm or allow anyone to hold it when in danger zone so that hand control cannot be accidentally activated.

▲ WARNING Never work on or around fairlead or winch when drum is under load.

▲ CAUTION Do not use winch to hold loads in place. Use other means of securing loads such as tie down straps.



25. It is recommended that if you are within four feet of the winch, do not hold the wire rope and the remote controller at the same time.
26. Mount the winch to a firm base. Be sure that your structural support is strong enough to withstand the rated pulling strength of the winch.
27. While mounting orientation is at your discretion, always remember that your winch is to be operated with the wire rope in an under-wound orientation on the wire rope drum. Your winch is designed to rope in and rope out in one direction. Do not attempt to reverse the operation of winch.

▲ CAUTION Do not weld or machine any part of the winch. Machining or welding may weaken the structural integrity of the winch and will void your warranty.

▲ DANGER Be aware that vehicle batteries contain gases that are flammable and can explode violently. The following precautions should be taken before making battery connection:

Wear eye protection;

Remove all jewelry;

Follow wiring diagram included in installation instruction;

Keep Spectators away.

In the event of a battery explosion acid should be flushed away immediately. Seek Medical help as soon as possible.

▲ CAUTION Use of any other accessories or attachment other than those recommended in the instruction manual may result in personal injury or property damage and could void warranty. Do not machine alterations may or weld any part of winch. Such weaken structural integrity of winch.



Nowow mechanical & electrical Corp., Ltd (Novawinch brand owner) offers a limited lifetime warranty on the mechanical components to authorised distributor & dealer of the winch subject to the following:

Novawinch Limited Lifetime Warranty:

The winch is used for permitted application use only. (expect design for it)

The limited lifetime warranty covers the purchaser of the winch against manufacturing defects in workmanship and materials on all mechanical components.

Mechanical components and associated parts have a lifetime warranty.

Electrical components consisting of solenoids, wiring, remotes, wire connectors and associated parts have a limited two (2) year warranty. Control Box and associated parts have a limited two (2) year warranty. Motor and associated parts have a limited two (2) year warranty

The warranty does not apply to the finish of the winch or components.

The owner will be responsible for removing the winch and returning it to an approved Novawinch authorised distributor or dealer within the warranty period.

All freight or delivery charges from the authorised distributor or dealer must be paid for by the owner of the winch unless specified by an authorised distributor or dealer.

Novawinch will not be liable for any fees, costs or charges associated from the removal or installation of the winch, whether or not the winch is under warranty.

Novawinch will repair or replace any or all of the faulty winch components, after an inspection by an authorised distributor or dealer has determined that some or all parts of the winch are defective hence are deemed to be replaced or fixed under warranty.

Novawinch Warranty Exclusions:

There are certain conditions that make the winch not eligible for warranty claims. The warranty is void if, but not limited to the following:

The winch is used in inappropriate applications.

The steel rope and synthetic rope are excluded from this warranty, unless specified otherwise by Novawinch, at the discretion of Novawinch.

The winch is damaged in any way from corrosion or water ingress.

The winch is returned in pieces.

The winch has been modified or disassembled resulting in failure.

Any winch component shows signs of normal wear and tear, damage from an accident, abuse, misuse, collision, overloading, modification, misapplication, improper installation or improper service or maintenance.

The winch was not purchased through the Novawinch Authorised Dealer Network.

**The warranty set forth above is the only warranty. Novawinch reserves the right to change the product design at any time without notice. Where this has happened, Novawinch shall have no obligation to upgrade or otherwise modify any previously manufactured products.*

34	Hexagon Socket Cap Screws M6×25	16	
35	Spring Washer 6	22	
36	Wire rope	1	
36	Synthetic rope	1	
37	Hook	1	
38	Hand Saver	1	
39	Roller Fairlead	1	Match with Wire rope
39	Aluminum hawse	1	Match with Synthetic rope
40	Switch	1	
41	Hardware	1ST	Match with Fairlead
41	Hardware	1ST	Match with Aluminum hawse

INSTALLATION

WINCH INSTALLATION

- The winch is to be mounted into a steel mounting frame using the 4 point foot mounting system in either a horizontal or vertical plane.
 - It's very important that the winch be mounted on a flat surface so that the three sections (motor, cable drum and gear housing) are properly aligned.
 - Before commencing installation ensure the mounting facility being used is capable of withstanding the winches rated capacity.
- Should you wish to manufacture your own mounting plate the dimensions below will assist. A steel mount plate 6mm thick is recommended. Fasteners should be steel high tensile grade 5 or better. A poorly designed mount may void warranty.
- The winch should be secured to the mounting with Grade 8.8 M10 bolts and spring washers provided (see Figure 4).

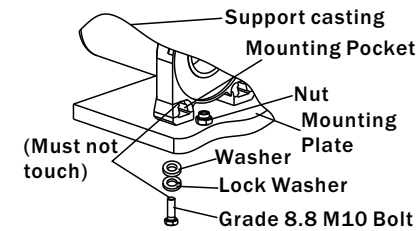

Figure 4

CAUTION Do not substitute any strength weaker than Grade 8.8 Grade marking is found on the bolt head and is pictured in Figure 5.

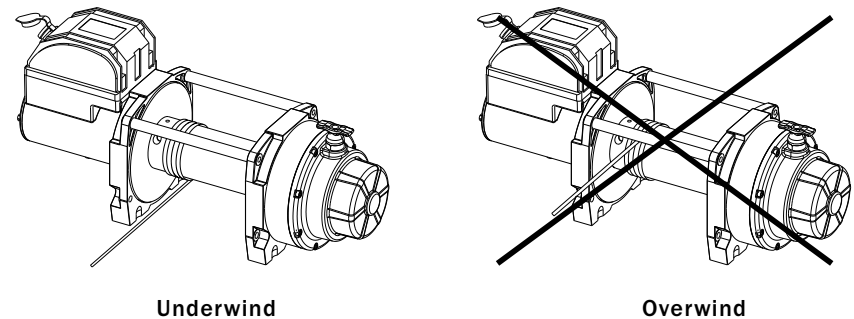

Figure 5

ELECTRICAL INSTALLATION

Winch operates on standard automotive 12VDC or 24VDC only.

DANGER Never connect winch to 110V AC house current or 220V mains as solenoid burnout or fatal shock may occur.

For normal self-recovery work, your existing electrical system is adequate. A full charged battery and proper connections are essential. Run the vehicle engine during winching operation to keep battery charged Pay close attention to proper electrical connection as follows:

NOTE: For best operation, battery with 440 cold cranking ampere capacity and a 60 amp alternator are the minimum recommended power soucer. Have the engine running when using the winch to avoid flattening the battery. If winch is in heavy use, an auxiliary battery and heavy duty alternator with battery isolator are recommended.

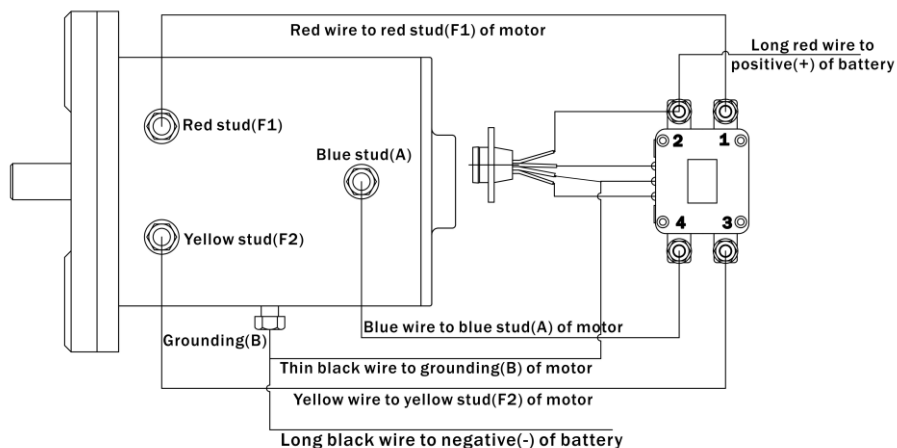

1. Red wire to connect the red stud(F1) of the motor and terminal 1 of the relay.
2. Yellow wire to connect the yellow stud(F2) of the motor and terminal 4 of the relay..
3. Blue wire to connect the blue stud(A) of the motor and terminal 3 of the relay.
4. Thin black wire connecting to grounding (B) of the motor.
5. Long black wire, one terminal connecting to the grounding (B) of the motor, and the other terminal connecting to negative (-) terminal of battery.
6. Long red wire connecting to positive (+) terminal of battery.

NOTE:

1. Your battery must be kept in good condition.
2. Be sure battery cables are not drawn across any surfaces, which could possibly damage them.
3. Corrosion on electrical connections will reduce performance or may cause a short-circuit.
4. Clean all connections especially in remote control switch and receptacle.
5. In salty environments use a silicone sealer to protect from corrosion.

PARTS LIST

ITEM	DESCRIPTION	QTY	OPTION
1	Hexagon Socket Cap Screws M6×40	1	For 8000 - 12000
2	Motor Assembly	1	For 8000 - 12000
3	Control Box	2	For 8000 - 12000
4	Tie Bar	3	For 8000-S - 12000-S
4	Tie Bar	1	For 8000 - 12000
5	Hexagon Socket Cap Screws M6×25	4	For 8000-S - 12000-S
6	Nut M6	1	
7	Seal Ring	2	
8	Slid Bearing	2	
9	Shaft-connector	1	
10	Hexagon Shaft I	1	
11	Cap Screws M6×25	4	
12	Drum	1	
13	Brake Coupling	1	
14	Brake Assembly	1	
15	Hexagon Shaft II	1	
16	Rub Reduce Washer II	1	
17	Clutch	1	
18	Hexagon Socket Set Screws With Cone Point M4×8	1	
19	Gear Box Frame	1	
20	Seal I	2	
21	3rd Stage Gear Ring	1	
22	Retaining Ring 105	1	
23	Control Box	1	For 8000-S - 12000-S
24	3rd Stage Planetary Gear Assembly	1	
25	Rub Reduce Washer I	1	
26	2 nd Stage Planetary Gear Assembly	1	
27	Rub Reduce Washer II	1	
28	1 st Stage Planetary Gear Assembly	1	
29	1 st Stage Sun Gear	1	
30	1,2 st Gear Ring	1	
31	Rub Reduce Washer I	1	
32	Slide Bearing	1	
33	Gear Box Body	1	

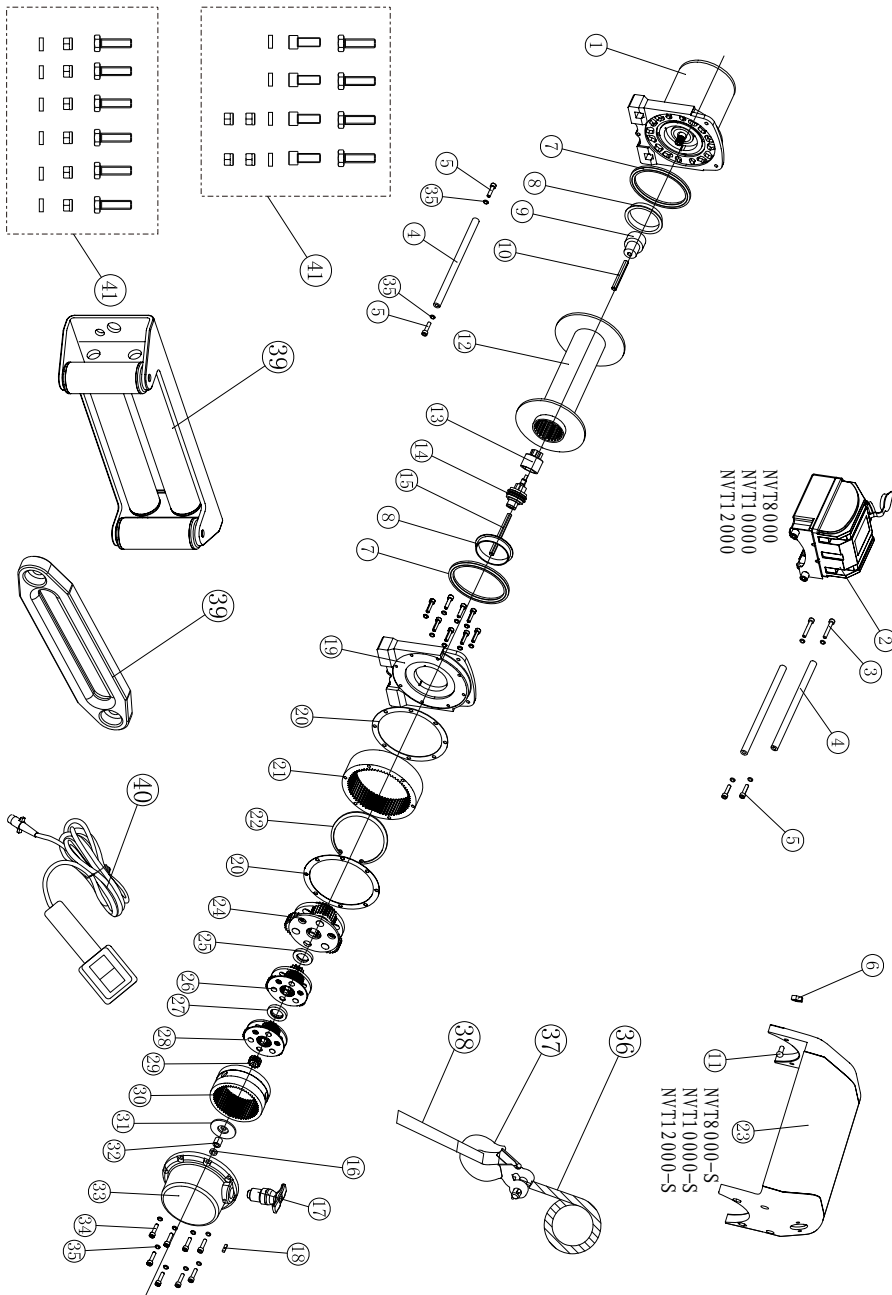

ELECTRICAL LEAD WIRE ATTACHMENT

1. Disconnect vehicle battery.
2. The battery lead wires should be routed to the battery. To ensure against insulation abrasion and/or cutting, apply several layers of electric tape where wiring may come in contact with sharp metal parts of vehicle. All connections to motor, solenoids and battery ground require good, clean, tight connections. Connect the red lead to the battery (+) and the black lead to the battery (-).
3. The relay may be mounted remotely as space requires. If assembly is located more than 27' (.7m) from winch, use a larger diameter wire.
4. Reconnect the battery positive then negative terminal. Rotate the clutch lever to the "disengaged" position. Pull several feet of cable off the drum. Return the clutch lever back to the "Engaged" position. Plug in remote switch assembly. Switch the hand control to "Rope-out" position. Pull trigger momentarily to check cable drum rotation direction. If drum rotates in the wrong direction, recheck your wiring.

▲ WARNING Double check wiring. Incorrect wiring could result in motor burnout and/or personal injury.

Operation

▲ CAUTION Switch assembly must be kept free of dirt and moisture to ensure safe operation.

1. The handheld switch activates power to the winch motor. To connect the control, remove the cover on the receptacle and insert the plug end of remote switch. The plug on the control cord is keyed and will fit into the socket only one way. The switch trigger returns to the "Off" position when released. To change direction, press the rocker in the other direction. (see Figure 6)

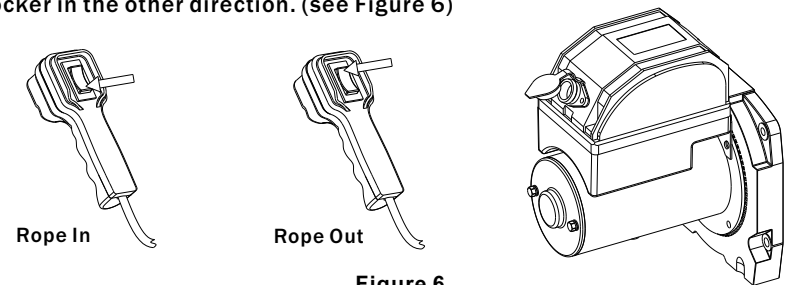

Figure 6

2. PULLING OUT THE WIRE ROPE

The wire rope has been installed on winch under minimal load at factory. It must be re-spooled onto the drum under load so the outer layers will not draw down into the inner layers, causing damage to cable.

- a) Pull and rotate the clutch lever to the, "Disengaged" position as shown in Figure 7. If there is a load on the wire rope, the clutch lever may not turn easily. **DO NOT FORCE THE CLUTCH LEVER.** Release tension on the wire rope by jogging out some of the wire rope, then try releasing the clutch.
- b) Pull out the wire rope and secure it to anchor or load.
- c) Check that there are at least five(5) turns of wire rope or eight(8) turns of synthetic rope left on the drum.
- d) Re-engage the drum by rotating the clutch lever to the, "Engaged" position (see Figure 7)

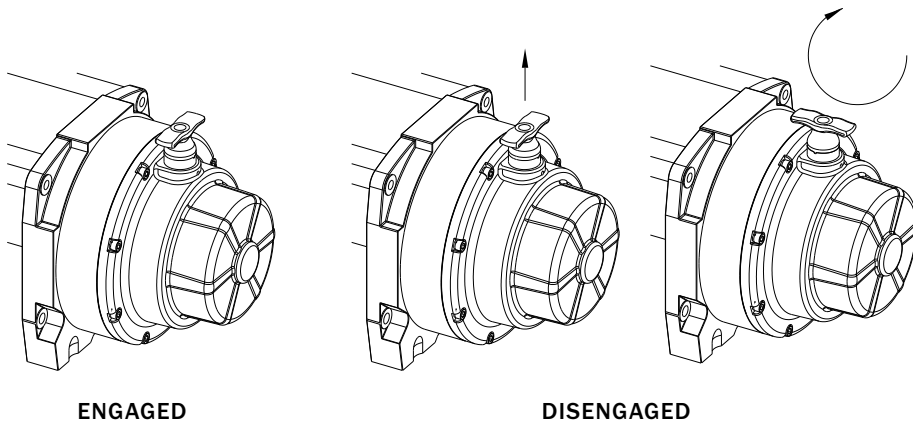

Figure 7

CAUTION Lever must be in the engaged position and locked before winching.

3. Your winch incorporates a proportional friction-type brake. After winching in a load, this mechanism holds the load, up to the rated capacity of the winch. While powering out the load, the winch controls the rate of speed by applying the brake in proportion to the amount of the load in the winch cable. This results in heavier loads powering-out more slowly than lighter loads. Similar to the friction-type brakes in your automobile which can generate heat if used for a long period of time, the winch brake can generate heat if used to power-out a load for a long period of time. To ensure optimum winch performance. Always limit powering out a load for 1 minute and allow the brake to cool for 15 minutes before continuing to winch. Under normal use, the brake mechanism should not require any adjustment. Should the brake fail to hold a load or maintain a constant rate of speed during power-out operation, the brake pad may be worn and require replacement.
4. Keep a tightly wound wire rope drum. Do not allow windings on drum to become loosely wound. A loosely wound drum allows wire rope under load to work its way down into layers of wire rope on drum. When this occurs, wire rope may become wedged within body of windings causing damage to wire rope. To prevent this, keep wire rope tightly and evenly wound on drum at all times. Rewind rope under tension after each use. One method is to attach the hook to a stationary object at top of a small hill or incline and winch your vehicle up incline.
5. Do not allow motor to overheat. Winch is designed for intermittent use only. During long or heavy pulls motor will get hot, with internal parts hotter than case. To check motor temperature, stop winching and carefully touch end of motor. If uncomfortably warm, allow motor to cool before continuing. Keep engine running to recharge battery during this break.
6. The pull required to start a load moving is often much greater than pull to keep it moving. Avoid stopping and starting during a pull except when required by motor temperature.
7. Prevent kinks before they occur. (see Figure 8).

12000lb Specifications	
Rated line pull	12000lbs(5443kgs)
Motor(Series wound)	DC 12V: 7.3hp/5.5kW
	DC 24V: 8.2hp/6.2kW
Gear train	3 stage gear-driven
Gear ratio	196:1
Clutch	Pull and turn
Braking action	Mechanical, Automatic load holding
Fairlead	4-way roller fairlead
Wire rope	3/8"×85.3'(9.2mm×26m)
Drum size	2.48"×8.8"(63mm×224mm)
Dimensions	22.36"×6.2"×10.3"(568mm×158mm×260mm)
	22.36"×6.2"×10.63"(568mm×158mm×270mm)
Bolt pattern	10"×4.5"(254mm×114.3mm)
Net weight	92bs(41.8kgs)
	95.2lbs(43.2kgs)

12V DC Line speed and motor current (first layer)							
Line pull	lbs	0	4000	6000	8000	10000	12000
	kgs	0	1816	2724	3629	4536	5443
Line speed	fpm	20	8.8	7.9	6.6	5.2	3.6
	mpm	6.1	2.7	2.4	2.0	1.6	1.1
Motor current	amps	80	210	260	320	380	460

24V DC Line speed and motor current (first layer)							
Line pull	lbs	0	4000	6000	8000	10000	12000
	kgs	0	1816	2724	3629	4536	5443
Line speed	fpm	15.1	7.9	6.6	5.6	4.9	3.6
	mpm	4.6	2.4	2	1.7	1.5	1.1
Motor current	amps	70	90	130	165	220	260

12000lb Line pull and cable capacity					
Layer of cable		1	2	3	4
Rated line pull per layer	lbs	12000	9563	7949	6801
	kgs	5443	4342	3609	3087
Cable capacity per layer	ft	17.7	40.4	67.3	85.3
	m	5.4	12.3	20.5	26

10000lb Specifications	
Rated line pull	10000lbs(4536kgs)
Motor(Series wound)	DC 12V: 6.3hp/4.5kW
	DC 24V: 6.9hp/5.2kW
Gear train	3 stage gear-driven
Gear ratio	196:1
Clutch	Pull and turn
Braking action	Mechanical, Automatic load holding
Fairlead	4-way roller fairlead
Wire rope	3/8"×85.3'(9.2mm×26m)
Drum size	2.48"×8.8"(63mm×224mm)
Dimensions	22.36"×6.2"×10.3"(568mm×158mm×260mm)
	22.36"×6.2"×10.63"(568mm×158mm×270mm)
Bolt pattern	10"×4.5"(254mm×114.3mm)
Net weight	92lbs(41.8kgs)
	95.2lbs(43.2kgs)

12V DC Line speed and motor current (first layer)						
Line pull	lbs	0	4000	6000	8000	10000
	kgs	0	1816	2724	3629	4536
Line speed	fpm	20	8.8	7.9	6.6	5.2
	mpm	6.1	2.7	2.4	2.0	1.6
Motor current	amps	80	210	260	320	380

24V DC Line speed and motor current (first layer)						
Line pull	lbs	0	4000	6000	8000	10000
	kgs	0	1816	2724	3629	4536
Line speed	fpm	17.7	10.5	8.8	6.6	5.6
	mpm	5.4	3.2	2.8	2.0	1.7
Motor current	amps	70	110	150	195	220

10000lb Line pull and cable capacity					
Layer of cable		1	2	3	4
Rated line pull per layer	lbs	10000	7900	6600	5600
	kgs	4536	3587	2996	2542
Cable capacity per layer	ft	17.7	40	66.9	85.3
	m	5.4	12.2	20.4	26

- a. This is the start of a kink. Wire rope should be straightened.
 - b. Wire rope was pulled and loop has tightened into a kink. wire rope is now permanently damaged and must be replaced.
 - c. Result of kinking is that each strand pulls a different amount causing strands under greatest tension to break and reduce load capacity of wire rope. The wire rope must be replaced.
8. Equipping winch with a roller fairlead will substantially reduce wear on wire rope during angle pulls, because rollers eliminate heavy rubbing and abrasion to wire rope. (See Figure 9).

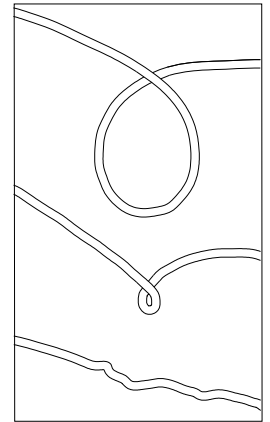

Figure 8

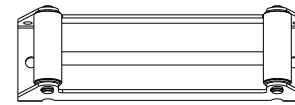

Figure 9

Note:

1. Never winch with your vehicle in gear or in park, which would damage your vehicle's transmission.
2. Never wrap the cable around the object and hook onto the cable itself. This can cause damage to the object being pulled, and kink or fray the cable.
3. Keep hands, clothing, hair and jewellery clear of the drum area and cable when winching.
4. Never use the winch if the cable is frayed, kinked or damaged.
5. Never allow anyone to stand near the cable, or in line with the cable behind the winch while it is under power. If the cable should slip or brake, it can suddenly whip back towards the winch, causing a hazard for anyone in the area. Always stand well to the side while winding.
6. Don't leave the switch plugged in when winch is not in use.

CHECK THE WINCH CAREFULLY AND THOROUGHLY BEFORE OPERATING!

Maintenance

It is highly recommended and that the winch be used regularly (once a month). Simply power the cable out 15m, free spool 5m and then power back in. This will keep all components in good working condition so that the winch can be relied on when needed. Contact your authorized outlet for technical assistance and repairs.

NOTE:

The safety precautions and instructions discussed in this manual can't cover all possible conditions and situations that may occur. It must be understood by the operator that common sense and caution are factors, which cannot be built into this product, but must be applied by the operator.

NOTICE:

1. Do not use winch as a hoist, do not use for transportation of people.
2. Do not operate and spool under full load over one minute continuously.
3. While motor is over heating, please stop for a while to cool down.
4. Limited lifetime warranty.

DIMENSIONS

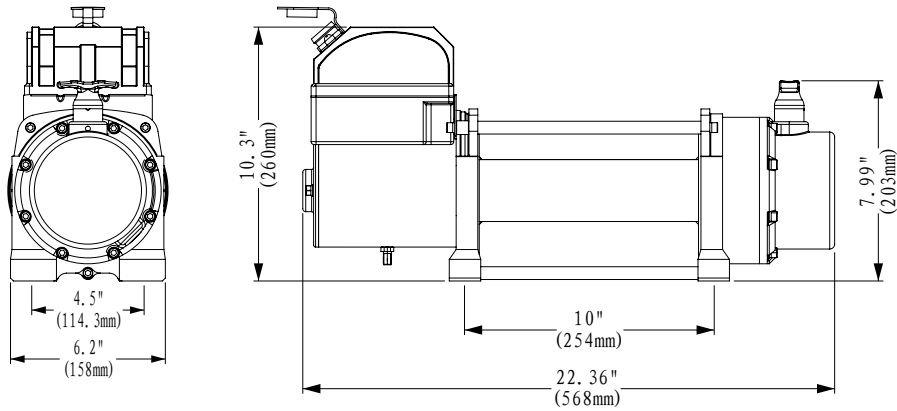

8000/10000/12000

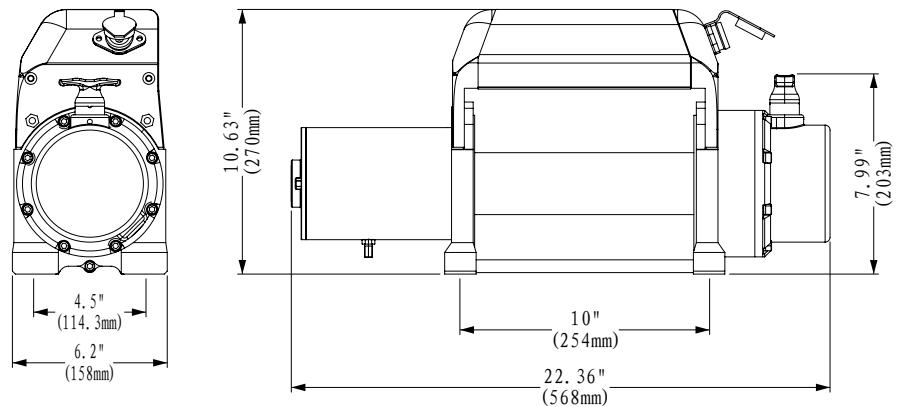

8000-S/10000-S/12000-S

PERFORMANCE SPECIFICATIONS

8000lb Specifications	
Rated line pull	8000lbs(3629kgs)
Motor(Series wound)	DC 12V: 5.6hp/4.2kW
	DC 24V: 5.8hp/4.3kW
Gear train	3 stage gear-driven
Gear ratio	196:1
Clutch	Pull and turn
Braking action	Mechanical, Automatic load holding
Fairlead	4-way roller fairlead
Wire rope	5/16"×95'(8.1mm×29m)
Drum size	2.48"×8.8"(63mm×224mm)
Dimensions	22.36"×6.2"×10.3"(568mm×158mm×260mm)
	22.36"×6.2"×10.63"(568mm×158mm×270mm)
Bolt pattern	10"×4.5"(254mm×114.3mm)
Net weight	91.6lbs(41.6kgs)
	94.7lbs(43kgs)

12V DC Line speed and motor current (first layer)						
Line pull	lbs	0	2000	4000	6000	8000
	kgs	0	908	1816	2724	3629
Line speed	fpm	19.4	12.2	9.8	8.2	5.6
	mpm	5.9	3.5	3.0	2.5	1.7
Motor current	amps	80	160	220	280	360

24V DC Line speed and motor current (first layer)					
Line pull	lbs	0	4000	6000	8000
	kgs	0	1816	2724	3629
Line speed	fpm	17.7	9.2	7.8	6.6
	mpm	5.4	2.8	2.5	2.0
Motor current	amps	60	90	130	175

8000lb Line pull and cable capacity					
Layer of cable		1	2	3	4
Rated line pull per layer	lbs	8000	6922	5389	5048
	kgs	3629	3142	2650	2292
Cable capacity per layer	ft	19.8	44.1	72.9	95
	m	6	13.4	22.2	29